

DOKON Baler

H-Series



Kadant PAAL's DOKON fully automatic channel baler's unique design makes the PAAL DOKON baler a powerful, efficient bale press with horizontal twine tying system. The PAAL DOKON baler provides a pressing force of 90 to 218 tons and offers a bale format of 32" x 44" or 44" x 44". The combination of high pressing force, independence from the cutting and compressing process, and patented pre-press setting combined with individual channel adjustment lead to high quality baling results.

Kadant PAAL was founded in 1854 in Osnabrück, Germany. Since its introduction of the first continuously operated horizontal baler in 1960, PAAL has delivered more than 30,000 machines and today is the #1 channel baler manufacturer in Europe.

PAAL®

DOKON Baler H-Series Overview



Features

- Optimised knife, stamper, and channel design
- Modern axial piston pumps with low drive power
- Advanced positional ram measurement system
- Twine tying



Benefits

- High throughput and bale weight
- Low energy consumption
- Easy disposal and no interference in a waste incineration process of the twine
- Low operation and maintenance costs
- Easy transport, storage, and handling of the spools
- Increased safety
- Low consumable costs by twine (approximately half the costs compared to wire)

Technical Data and Measurements

DOKON H-Series		275 H			500 H			600 H			700 H		
Pressing force	t (kN)	82 (802)			122 (1.197)			158 (1.546)			198 (1.940)		
Spec. pressing force	N/cm ²	91			99			128			160		
Tunnel cross section	cm	80 x 110			110 x 110			110 x 110			110 x 110		
Hopper opening	cm	160 x 102			200 x 102			200 x 102			200 x 102		
Feeding volume	ca. m ³	2.1			3.45			3.45			3.45		
Number of twine tyings	pieces	4			5			5			5		
Driving power	kW	15	55	2 x 45	45	55	2 x 75	2 x 37	2 x 55	3 x 75	2 x 45	3 x 55	4 x 75
Press output (ideal)	max. m ³ /h	304	610	720	430	650	1135	630	930	1,265	520	1,070	1,325
Press output (under load – 100 kg/m ³)	max. m ³ /h	106	300	370	250	325	600	340	480	725	315	575	800
Press Capacity (Weight at RDF)													
• 100 kg/m ³	ca. t/h	10.5	30	37	25	33	60	34	48	72.5	31.5	57.5	80
• 150 kg/m ³	ca. t/h	14.5	38	48	30	39	72	40.5	58	87	37.5	69	96
• 200 kg/m ³	ca. t/h	18	41	51	35	46	84	48	67	102	44	81	112

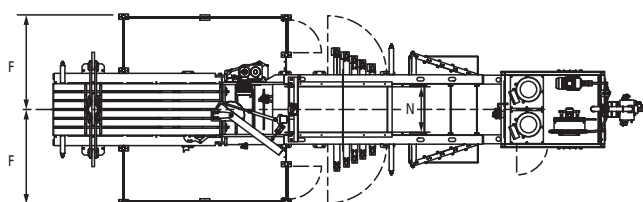
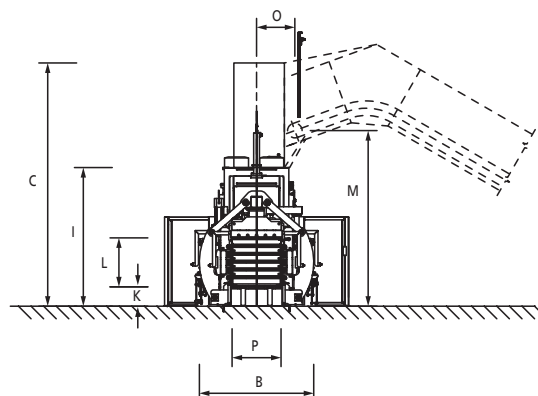
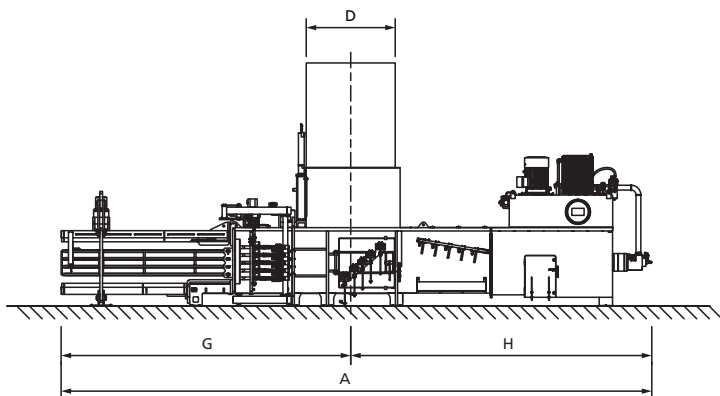

	A	B	C	D	F	G	H	I	K	L	M	N	O	P
DOKON 275 H	11500	2354	5185	1600	2050	5307	6193	2835	435	800	3650	1020	920	1100
DOKON 500 H	13300	2569	5465	2000	2050	6507	6793	3115	435	1100	3930	1020	920	1100
DOKON 600 H	13800	2684	5465	2000	2050	7007	6793	3115	435	1100	3930	1020	920	1100
DOKON 700 H	14650	2684	5465	2000	2050	7707	6943	3115	435	1100	3930	1020	920	1100

Dimensions are in millimetres.

Specifications are for reference only and subject to change.